

**DO NOT OPEN THE EXAMINATION PAPER UNTIL
YOU ARE TOLD BY THE SUPERVISOR TO BEGIN**

**PHYSICS 2204
MIDTERM EXAMINATION
2009/2010**

Value: 100 marks

Time: 3 hours

GENERAL INSTRUCTIONS

1. This is a two-part test. All parts are contained in this booklet. The examination consists of items arranged as follows:
SECTION I – 50 selected response items – Do ALL items – 50%
SECTION II – constructed response items – Do ALL items – 50%
2. **Section I** may be answered using the answer sheet provided. Instructions for completing this answer sheet are given on the sheet itself. Please complete it according to those instructions and any other given by the supervisor.
3. **Section II** – is to be answered in the spaces provided in this test booklet. Please pass in the entire test to the supervisor when you have finished the examination.
4. Rough work may be done in any blank spaces in this test booklet.

REGULATIONS FOR CANDIDATES

Candidates are expected to be thoroughly familiar with all regulations pertaining to their conduct during the examinations. These were explained by the chief supervisor prior to the first session, and have been posted for further reference near the entrance to the examination room. Candidates should ensure that they understand and comply with all requirements governing the following matters:

- Materials required
- Materials not permitted
- Models of calculators permitted
- Use of pen or pencil
- Communication and movement during the examination
- Use of unauthorized means, and penalties
- Punctuality
- Leaving the room
- Use of answer booklets
- Completion of required information

PART I
Total Value: 50%

Instructions: Shade the letter of the correct answer on the computer scorable answer sheet provided.

- 1 What is 15 m/s expressed in km/h?
 - A. 0.9 km/h
 - B. 4.2 km/h
 - C. 54 km/h
 - D. 250 km/h

- 2 Which one of the following contains two vectors?
 - A. acceleration, distance
 - B. acceleration , time
 - C. distance, velocity
 - D. force, velocity

- 3 Which statement is true?
 - A. Displacement can never be equal to distance.
 - B. Displacement can never be greater than distance.
 - C. Displacement can never be less than distance.
 - D. Displacement is always equal to distance.

- 4 Which of the following is an example of uniform motion?
 - A. A ball is dropped out of a window.
 - B. A football is thrown in the air and caught 30 m away.
 - C. An elevator comes to a stop.
 - D. A marble rolls on a flat table.

- 5 Which statement best describes the motion of the object at $t = 3$ s?
 - A. Decreasing speed to the left
 - B. Decreasing speed to the right
 - C. Increasing speed to the left
 - D. Increasing speed to the right

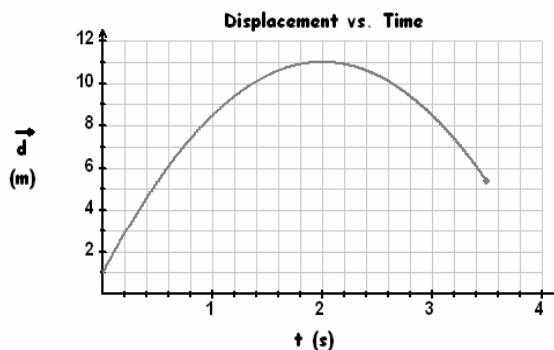

- 6 On a displacement vs. time graph, what does a sloping straight line represent?
 - A. Constant displacement
 - B. Constant speed
 - C. Constant velocity
 - D. Uniform acceleration

- 7 During which section of the velocity-time graph shown at the right would a corresponding displacement-time graph produce a straight line with a slope?
 - A. A
 - B. B
 - C. C
 - D. D

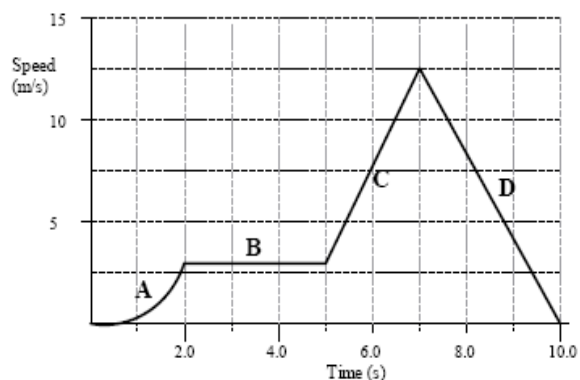

- 8 A car's motion is described by the velocity versus time graph shown. What is the total displacement of the car during its motion?
- A. 45 m
 B. 90 m
 C. 110 m
 D. 140 m

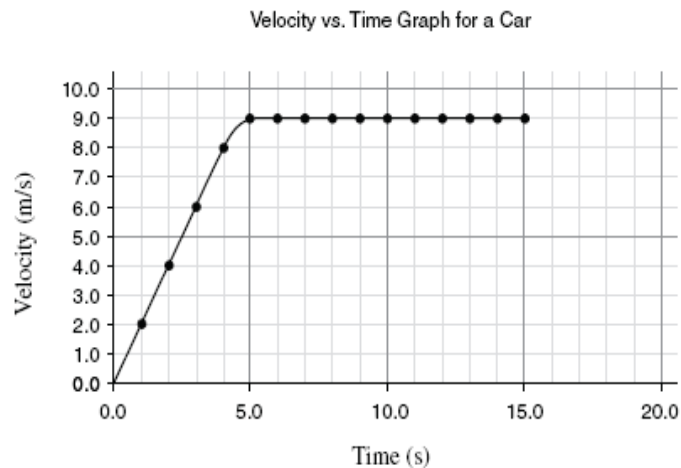

The next TWO (2) questions deal with the following graph.

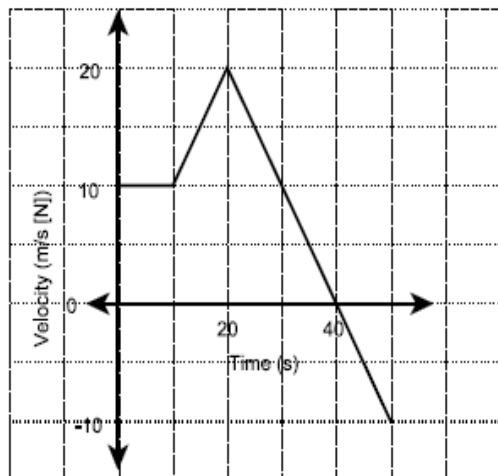

- 9 What is the displacement of the biker from 0 to 50 s?
- A. 400 m [N]
 B. 400 m [S]
 C. 500 m [N]
 D. 500 m [S]
- 10 What is the instantaneous acceleration at 40 s?
- A. 0 m/s^2 [S]
 B. 0.5 m/s^2 [N]
 C. 1.0 m/s^2 [N]
 D. 1.0 m/s^2 [S]
- 11 A skateboarder rolls down a hill and then up the other side. Which graph most accurately depicts the motion?

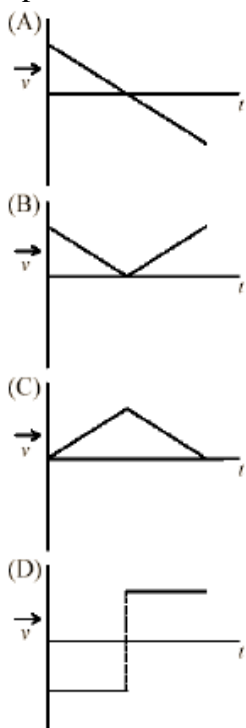

- 12 The velocity of two objects is represented on the graph below. Which is true at point X?

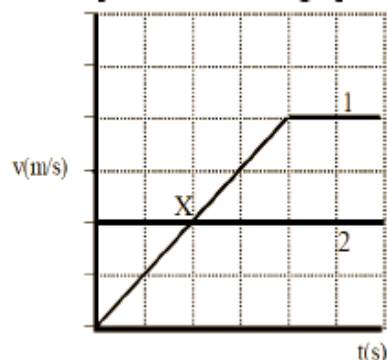

- A. Both objects have the same acceleration.
B. Both objects have the same displacement.
C. Object 2 has a greater acceleration than object 1.
D. Object 2 has a greater displacement than object 1.
- 13 An object is thrown vertically upward from the Earth. While it is rising what is true of its velocity and acceleration?
A. Its velocity is decreasing and its acceleration is increasing
B. Its velocity is decreasing but its acceleration remains the same.
C. Its velocity is downward but its acceleration remains the same.
D. Its velocity is increasing and its acceleration is upward
- 14 What is the average velocity for a car that travels 300.0 km due East in 2.0 hours and then turns and travels 100.0 km due West in one half hour?
A. 80 km/h East
B. 80 km/h West
C. 160 km/h East
D. 160 km/h West
- 15 On one leg of a trip, an airplane travels 6.0×10^2 km/h for 2.0 h and 1200 km/h for 3.0 h. What is the average speed of the airplane?
A. 140 km/h
B. 360 km/h
C. 900 km/h
D. 960 km/h
- 16 A ball is dropped on a hard floor and bounces. It hits the floor with a speed of 10.0 m/s and bounces back with a speed of 7.00 m/s. The ball was in contact with the floor for only 28.0 ms. What was the acceleration of the ball for that time?
A. 0.107 m/s^2 [up]
B. 0.607 m/s^2 [up]
C. 107 m/s^2 [up]
D. 607 m/s^2 [up]
- 17 What is the acceleration of a scooter if it travels 12 m each second for 5.0 s?
A. 0 m/s^2
B. 2.4 m/s^2
C. 7.0 m/s^2
D. 12 m/s^2
- 18 A jet plane touches down and comes to a complete stop in 45 s, while covering a distance of 1600 m. What was the speed of the plane as it first touched down if it decelerated uniformly?
A. 18 m/s
B. 36 m/s
C. 71 m/s
D. 142 m/s

- 19 A ball is thrown vertically upward at 20 m/s from a height of 30 m above the ground. What is its speed on impact with the ground below?
- A. 14 m/s
 - B. 24 m/s
 - C. 31 m/s
 - D. 44 m/s
- 20 An astronaut on the moon throws a 5.0 kg wrench vertically upwards with an initial speed of 15 m/s. The acceleration due to gravity on the surface of the moon is one-sixth that on the surface of the earth. What is the maximum height reached by the wrench?
- A. 25 m
 - B. 46 m
 - C. 69 m
 - D. 75 m
- 21 An 1800 kg car initially travelling at 15 m/s brakes to avoid hitting another car. The car accelerates at 1.9 m/s^2 while braking to a stop. How far does the car travel during its acceleration?
- A. 29 m
 - B. 59 m
 - C. 120 m
 - D. 180 m
- 22 How long does it take a car to slow down from a speed of 54 km/h to 32 km/h over a distance of 65 m?
- A. 1.5 s
 - B. 2.7 s
 - C. 5.4 s
 - D. 5.9 s
- 23 A Jaguar is pursuing a fleeing Impala. The cars were initially separated by a distance of 50.0 m. If the Jaguar maintains an average speed of 15 m/s and the Impala an average speed of 8.0 m/s, how long will the contest last?
- A. 2.2 s
 - B. 3.8 s
 - C. 7.1 s
 - D. 160 s
- 24 If a ball is thrown vertically upwards at 15 m/s, how much time will elapse until it returns to the same point from which it was thrown?
- A. 0.65 s
 - B. 1.3 s
 - C. 1.5 s
 - D. 3.0 s
- 25 While standing on a ladder, 10.0 m above ground, a person tosses a ball vertically upwards with a speed of 5.2 m/s. Find its position after 2.0 s.
- A. 9.2 m above the person
 - B. 9.2 m below the person
 - C. 10.4 m above the person
 - D. 46 m above the person
- 26 A car accelerates uniformly from 20.0 km/h to 45 km/h in 12 minutes. What is its acceleration?
- A. 2.1 km/h^2
 - B. 43 km/h^2
 - C. 125 km/h^2
 - D. 210 km/h^2

- 27 A ball is thrown vertically upwards. What is the value of the acceleration when it has reached its maximum height?
- A. -9.8 m/s^2
 B. 0 m/s
 C. 0 m/s^2
 D. 9.8 m/s^2
- 28 A car is initially travelling at 50.0 km/h . The brakes are applied and the car stops over a distance of 35 m . What was magnitude of the car's acceleration while it was braking?
- A. 2.8 m/s^2
 B. 5.4 m/s^2
 C. 9.8 m/s^2
 D. 36 m/s^2
- 29 A car travelling along a road begins accelerating with a constant acceleration of 1.5 m/s^2 in the direction of motion. After travelling 392 m at this acceleration, its speed is 35 m/s . What was the speed of the car when it began accelerating?
- A. 1.5 m/s
 B. 2.3 m/s
 C. 7.0 m/s
 D. 34 m/s
- 30 Balloon A is moving upwards at 4.8 m/s and balloon B is moving upwards at 1.2 m/s . What is the velocity of balloon A relative to balloon B?
- | | Magnitude | Direction |
|----|-------------------|-----------|
| A. | 3.6 m/s | [down] |
| B. | 3.6 m/s | [up] |
| C. | 6.0 m/s | [down] |
| D. | 6.0 m/s | [up] |

- 31 Consider the two vectors shown below.

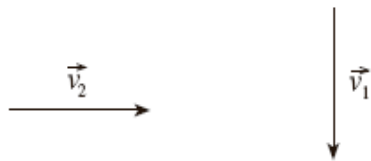

Which of the choices given best represents $v_1 + v_2$?

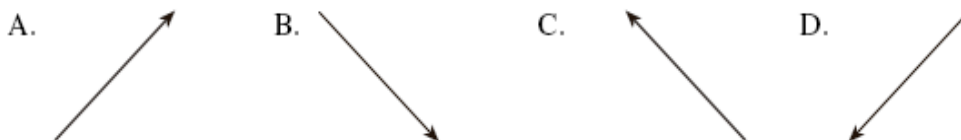

- 32 An airplane heading due east at 215 km/h is blown off course by a strong wind of 65 km/h blowing 45° south of west.

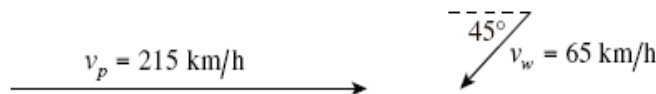

What is the resultant speed of the plane?

- A. 150 km/h
 B. 180 km/h
 C. 260 km/h
 D. 280 km/h

- 33 A subway train is moving at a constant velocity to the right. A rider on the train throws a ball vertically into the air and catches it. Which path would the ball take, as seen by an observer standing on the platform watching the train go by?

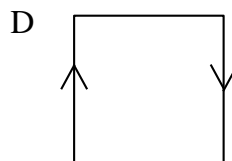
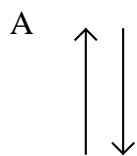

- 34 Two velocity vectors, v_1 and v_2 are shown.

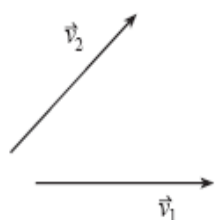

Which of the following best represents the resultant of the addition of the two velocity vectors?

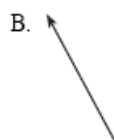
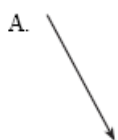

- 35 A pilot wants to fly due north from the departure point. During the flight there is a wind blowing from the east. What direction must the pilot point the plane during the flight?

- A. Due east
- B. Due west
- C. East of north
- D. West of north

- 36 Two displacement vectors of magnitudes 21 cm and 79 cm are added. Which one of the following is the only possible choice for the magnitude of the resultant?

- A. 0 cm
- B. 28 cm
- C. 37 cm
- D. 82 cm

- 37 A hiker leaves base camp and hikes 5.0 km [N] then turns to the west and continues another 7.0 km [W]. What is her displacement at that point?

- A. 8.6 km [N 54° W]
- B. 8.6 km [W 54° N]
- C. 8.6 km [NW]
- D. 12.0 km [N 36° W]

38. Which of the following vectors is the same as 26 m/s [W 78°S]?
- 26 m/s [E 78°N]
 - 26 m/s [W 12°S]
 - 26 m/s [S 12°W]
 - 26 m/s [S 78°W]
39. A displacement vector is 65 km in length and is directed [N 35° W]. What are the components of this vector?
- | | Westward Component | Northward Component |
|----|--------------------|---------------------|
| A. | 37 km | 0 km |
| B. | 37 km | 53 km |
| C. | 53 km | 37 km |
| D. | 53 km | 53 km |
40. What is defined as the velocity of a moving object as observed from another moving object?
- Associated velocity
 - Comparative velocity
 - Differential velocity
 - Relative velocity
41. Inertia is directly related to which of the following quantities?
- Acceleration
 - Mass
 - Velocity
 - Weight
42. Which of the following correctly represents the gravitational field strength of the earth at its surface?
- 9.8 N
 - 9.8 kgm/s²
 - 9.8 N/kg²
 - 9.8 N/kg

43. The diagram at the left shows two forces acting on a truck. F_1 has a magnitude of 35 N and is acting at an angle of 20° above the horizontal. F_2 has a magnitude of 51 N and is acting at an angle of 30° below the horizontal. What is the net *horizontal* force acting on the truck?

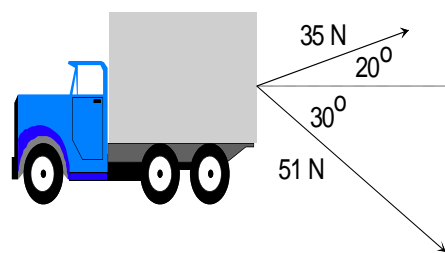

44. Which statement is always true regarding normal forces?
- They act to cancel out all other forces acting in the y-direction
 - They are directed toward the surface of the earth.
 - They are equal in magnitude but opposite in direction to gravitational forces.
 - They are exerted on an object by a surface on which the object is resting.
45. A curling rock is travelling to the right across the ice as shown in the diagram.



Which of the following best represents the forces acting on the curling rock?

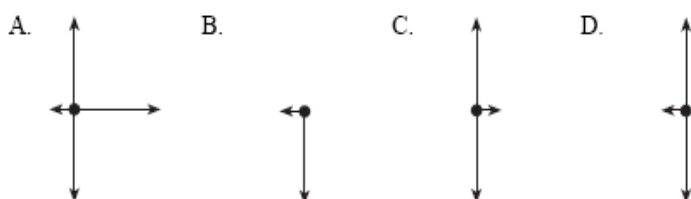

- 46 If you are in a spacecraft moving away from the Earth what is happening to your weight and mass?
- Both your mass and your weight are increasing.
 - Both your mass and your weight are decreasing.
 - Your mass decreases while your weight remains constant.
 - Your weight decreases while your mass remains constant.

- 47 Which of the following fundamental forces is the strongest?
- Electric
 - Gravitational
 - Strong nuclear
 - Weak nuclear

- 48 An object is travelling at constant speed across a desk. Which free body diagram represents the object?

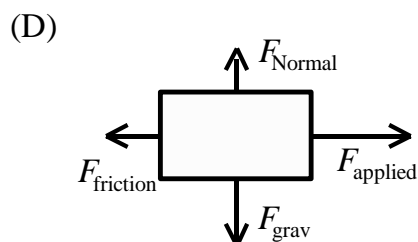
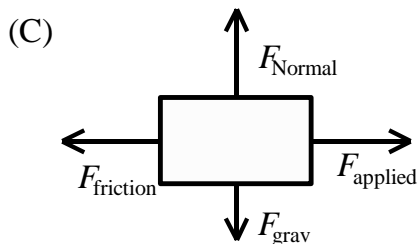
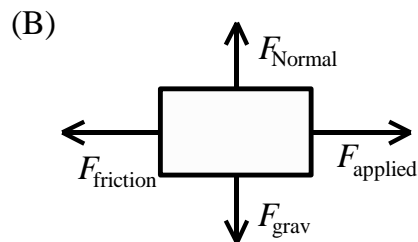
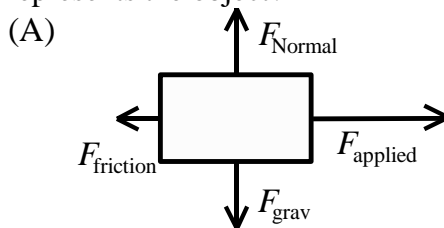

- 49 A 450 N chandelier is supported by three cables as shown in the diagram. What is the tension in the horizontal cable?
- 46 N
 - 260 N
 - 450 N
 - 520 N

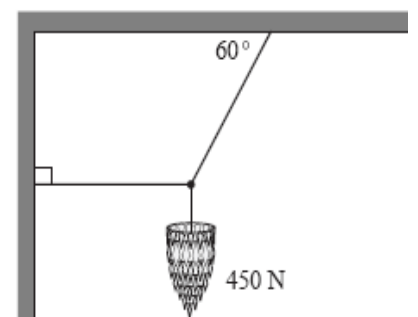

- 50 A book is at rest on a desk. Which of the following statements concerning the book is correct?
- The desk exerts no force on the book.
 - The book exerts no force on the desk.
 - There are no forces acting on the book.
 - The forces acting on the book are balanced.

PART II
Total Value: 50%

Instructions: Complete all items in this section. Your responses should be clearly presented in a well organized manner with proper use of units, formulae and significant figures where appropriate.

Value

4%

51.

A

Draw a position-time graph for a runner who moves at 3.5 m/s for 10 s, then at 1.5 m/s for 20 s, -2.5 m/s for 10 s, then -4.0 m/s for 10 s.

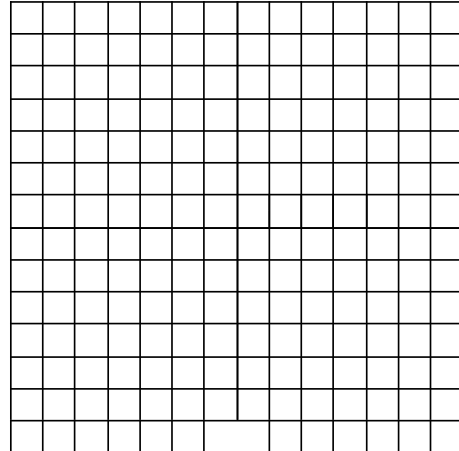

B

A car travelling at 12.0 m/s passes a stopped truck. **Four seconds** after the car passes, the truck accelerates from rest at 3.00 m/s^2 until it reaches 18m/s. Then the truck continues at a speed of 18 m/s.

3%

(i) Plot a velocity - time graph for the car and the truck on the grid.

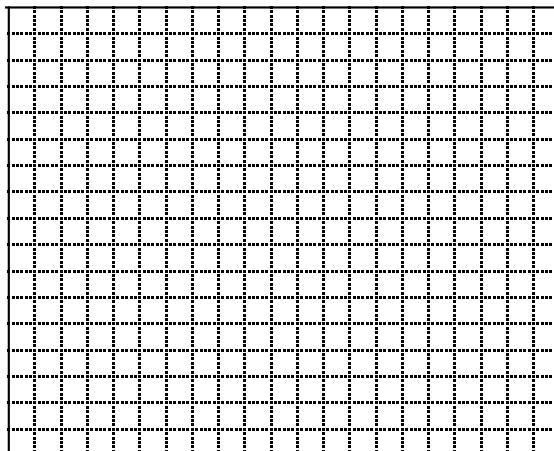

5%

(ii) When did truck catch the car?

3% 52. A A student stands on a cliff 120 m high and tosses a ball upward with some initial velocity. The ball strikes the ground 7.3s later. What was the ball's initial velocity?

4% B You are standing at the top of a cliff, 65.0 m above the water level and you throw the ball upward at a velocity of 28.0 m/s. How much time will elapse before the ball strikes the ground?

C A motorist is driving along a city street with a velocity of 60.0 km/h [E]. The motorist sees a soccer ball roll onto the street. It takes the motorist 0.760 s to react and then start to brake.

1% (i) What is the displacement of the vehicle before the motorist starts to brake?

2% (ii) If the acceleration of the car is 8.10 m/s^2 [W], how long does the car take to come to a complete stop?

2% (iii) What is the total displacement of the car before it comes to a complete stop?

56. A plane wants to fly directly south. The plane has an air speed of 450.0 km/h and is flying into the wind that is blowing at 95 km/h west.

3% A What should be the plane's heading?

2% B What is the plane's ground speed?

1% C How long will it take the plane to fly 1500 km [S]?

3% 57. A 30.0 kg sign is hung by a cable held off from the building by a bracket. The cable makes an angle of 40.0° with the horizontal. Determine the force exerted on the cable?

