

## Section 1.7: Solving Problems Involving Composite Objects

**Composite object:** comprises (is made of) two or more distinct objects.

To determine the volume of a composite object, identify the distinct objects, calculate the volume of each object and then add.

To calculate the area of a composite object, determine the faces that comprise the area. Then calculate the sum of the areas of these faces. (overlap)

1. Determine the volume of the composite figure to the nearest cubic inch.

Approach: Volume of Large Cylinder + Cone -  
Volume of small cylinder

$$\begin{aligned} V_{LC} &= \pi r^2 h \\ &= \pi (2)^2 (5) \\ &= 62.83 \text{ in}^3 \end{aligned}$$

Volume  $\Rightarrow$   
Apex  
height

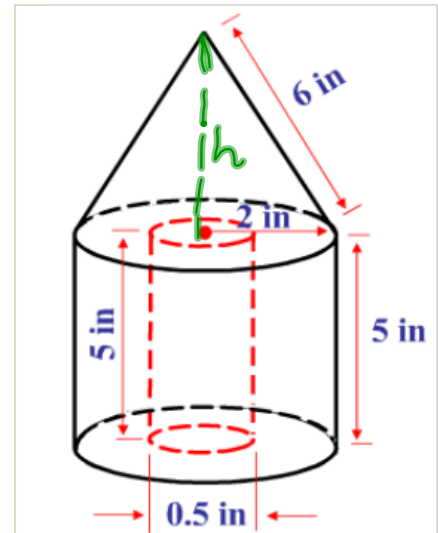

$$\begin{aligned} V_{sc} &= \pi r^2 h \\ &= \pi (0.25)^2 (5) \\ &= 0.98 \text{ in}^3 \end{aligned}$$

$$\begin{aligned} V_{\text{cone}} &= \frac{1}{3} \pi r^2 h \\ &= \frac{1}{3} \pi (2)^2 (\sqrt{32}) \\ &= 23.695 \text{ in}^3 \end{aligned}$$

Need Apex height

$$\begin{aligned} a^2 &= c^2 - b^2 \\ a^2 &= 6^2 - 2^2 \\ a^2 &= 32 \\ a &= \sqrt{32} \end{aligned}$$

$$\begin{aligned} V &= V_{LC} + V_{\text{cone}} - V_{sc} \\ &= 62.83 + 23.695 - 0.98 \\ &= 85.5 \text{ in}^3 \end{aligned}$$

2. Determine the volume of the composite object.

Approach: (Volume = Apex height)

$$V_{\text{prism}} + V_{\text{pyramid}}$$

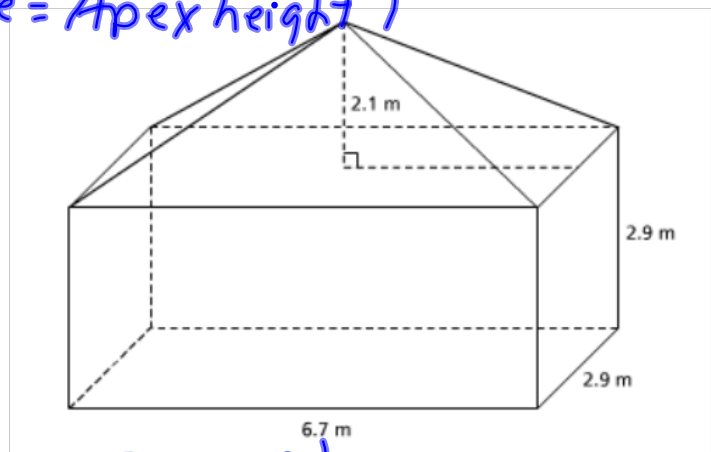

Prism

$$\begin{aligned} V &= lwh \\ &= (6.7)(2.9)(2.9) \\ &= 56.347 \text{ m}^3 \end{aligned}$$

Pyramid

$$\begin{aligned} V &= \frac{1}{3}lwh \\ &= \frac{1}{3}(6.7)(2.9)(2.1) \\ &= 13.601 \text{ m}^3 \end{aligned}$$

$$\begin{aligned} V_{\text{total}} &= V_{\text{prism}} + V_{\text{pyramid}} \\ &= 56.347 + 13.601 \\ &= 69.9 \text{ m}^3 \end{aligned}$$

3. Determine the volume.

Approach:  $V_{HS} + V_C$

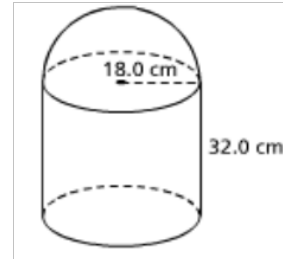

$$\begin{aligned} V_{\text{cylinder}} &= \pi r^2 h \\ &= \pi (18)^2 (32) \\ &= 32\,572.03 \text{ cm}^3 \end{aligned}$$

$$\begin{aligned} V_{HS} &= \frac{1}{2} V_{\text{sphere}} \\ &= \frac{1}{2} \left( \frac{4}{3} \pi r^3 \right) \\ &= \frac{2}{3} \pi r^3 \\ &= \frac{2}{3} \pi (18)^3 \\ &= 12\,214.51 \text{ cm}^3 \end{aligned}$$

$$\begin{aligned} V_{\text{Total}} &= 32\,572.03 + 12\,214.51 \\ &= 44\,786.5 \text{ cm}^3 \end{aligned}$$

4. Find surface area and volume. Slant Height  
↑ Apex Height

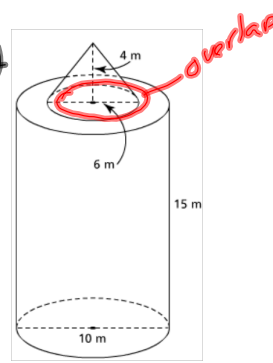

$$V_T = V_{\text{cone}} + V_{\text{cylinder}}$$

$$V_{\text{cone}} = \frac{1}{3} \pi r^2 h$$

$$V_{\text{cone}} = \frac{1}{3} \pi (3)^2 (4) \\ = 37.7 \text{ m}^3$$

$$V_{\text{cylinder}} = \pi r^2 h \\ = \pi (5)^2 (15) \\ = 1178.1 \text{ m}^3$$

$$V_T = 37.7 + 1178.1 = 1215.8 \text{ m}^3$$

$$SA_{\text{cylinder}} = 2\pi r h + 2\pi r^2 \\ = 2\pi (5)(15) + 2\pi (5)^2 \\ = 628.32 \text{ m}^2$$

$$SA_{\text{cone}} = \pi r s + \pi r^2$$

⇒ Need slant height

$$SA_c = \pi (3)(5) + \pi (3)^2$$

$$SA_c = 75.4 \text{ m}^2$$

$$s^2 = 3^2 + 4^2$$

$$s^2 = 9 + 16$$

$$s^2 = 25$$

$$s = \sqrt{25}$$

$$s = 5$$

Overlap:  $A = \pi r^2$   
 $= \pi (3)^2$   
 $= 28.27 \text{ m}^2$

$$SA_{\text{Total}} = SA_{\text{cylinder}} + SA_{\text{cone}} - 2(\text{Overlaps})$$

$$SA_{\text{Total}} = 628.32 + 75.18 - 2(28.27)$$

$$SA_T = 646.96 \text{ m}^2$$

5. A tool shed is formed by a rectangular prism with a triangular prism as its roof. Determine the surface area of the tool shed to the nearest square foot.

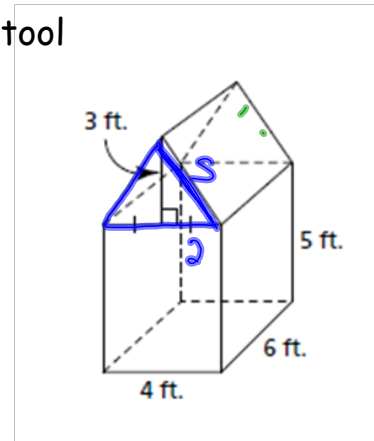

$$s^2 = 3^2 + 2^2$$

$$s^2 = 9 + 4$$

$$s^2 = 13$$

$$s = \sqrt{13}$$

Roof

$$\begin{aligned} 2 \text{ Rectangles } A &= 2lw \\ &= 2(6)(\sqrt{13}) \\ &= 12\sqrt{13} \\ &= 43.27 \text{ ft}^2 \end{aligned}$$

$$\begin{aligned} 2 \text{ Triangles: } A &= 2\left(\frac{1}{2}bh\right) \\ A &= bh \\ A &= (4)(3) \\ &= 12 \text{ ft}^2 \end{aligned}$$

Prism

$$\begin{aligned} \text{Front/Back: } A &= 2lw \\ &= 2(4)(5) \\ &= 40 \text{ ft}^2 \end{aligned}$$

$$\begin{aligned} \text{Sides: } A &= 2lw \\ &= 2(6)(5) \\ &= 60 \text{ ft}^2 \end{aligned}$$

$$\begin{aligned} \text{Bottom: } A &= lw \\ &= 4 \times 6 \\ &= 24 \text{ ft}^2 \end{aligned}$$

$$\begin{aligned} \text{TSA} &= 43.27 \text{ ft}^2 + 12 \text{ ft}^2 + 40 \text{ ft}^2 + 60 \text{ ft}^2 + 24 \text{ ft}^2 \\ &= 179.27 \text{ ft}^2 \\ &= 179 \text{ ft}^2 \end{aligned}$$