

**DO NOT OPEN THE EXAMINATION PAPER UNTIL  
YOU ARE TOLD BY THE SUPERVISOR TO BEGIN**

**PHYSICS 3204  
MIDTERM EXAMINATION  
2008/2009**

**Value: 100 marks**

**Time: 3 hours**

**GENERAL INSTRUCTIONS**

1. This is a two-part test. All parts are contained in this booklet. The examination consists of items arranged as follows:  
*SECTION I – 50 selected response items – Do ALL items – 540%*  
*SECTION II – constructed response items – Do ALL items – 50%*
2. **Section I** may be answered using the answer sheet provided. Instructions for completing this answer sheet are given on the sheet itself. Please complete it according to those instructions and any other given by the supervisor.
3. **Section II** – is to be answered in the spaces provided in this test booklet. Please pass in the entire test to the supervisor when you have finished the examination.
4. Rough work may be done in any blank spaces in this test booklet.

**REGULATIONS FOR CANDIDATES**

Candidates are expected to be thoroughly familiar with all regulations pertaining to their conduct during the examinations. These were explained by the chief supervisor prior to the first session, and have been posted for further reference near the entrance to the examination room. Candidates should ensure that they understand and comply with all requirements governing the following matters:

- Materials required
- Materials not permitted
- Models of calculators permitted
- Use of pen or pencil
- Communication and movement during the examination
- Use of unauthorized means, and penalties
- Punctuality
- Leaving the room
- Use of answer booklets
- Completion of required information

**PART I**  
**Total Value: 50%**

**Instructions: Shade the letter of the correct answer on the computer scorable answer sheet provided.**

1. Which illustrates projectile motion?  
(A) driving a car around a banked curve  
(B) dropping a rock from a building  
(C) juggling  
(D) running

2. A projectile is launched horizontally from a cliff edge as shown. What is the projectile's vertical speed 2.0 s into the flight?  
(A) 15 m/s  
(B) 20 m/s  
(C) 30 m/s  
(D) 150 m/s

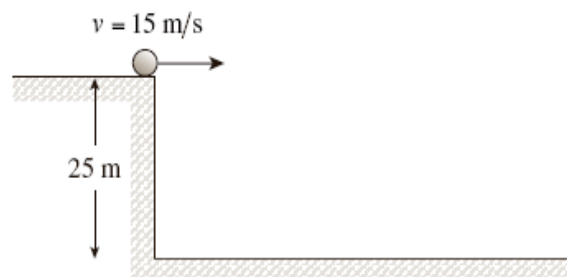

3. What is the maximum height of a projectile launched at 120 m/s at an angle of  $30.0^\circ$  above the horizontal?  
(A) 3.1 m  
(B) 5.3 m  
(C) 180 m  
(D) 550 m
4. A plane flying horizontally with a speed of 50.0 m/s at a height of 161 m drops a package when it is directly over a tent. How far from the tent will the package land?  
(A) 161 m  
(B) 169 m  
(C) 287 m  
(D) 1640 m
5. A stone is thrown upward from the top of a building at an angle of  $30.0^\circ$  to the horizontal with an initial speed of 20.0 m/s. If the stone lands on the ground 4.22 s later, how tall is the building?  
(A) 14.2 m  
(B) 21.5 m  
(C) 45.1 m  
(D) 129 m
6. A tennis ball is thrown from ground level with velocity  $v_1$  directed  $30^\circ$  above the horizontal. If it takes the ball 3.0 s to reach the top of its trajectory, what is the magnitude of the initial velocity?  
(A) 14.7 m/s  
(B) 29.4 m/s  
(C) 33.9 m/s  
(D) 58.8 m/s
7. Which is constant for any given projectile?  
(A) horizontal displacement  
(B) horizontal velocity  
(C) vertical displacement  
(D) vertical velocity





8. If a coin is pushed horizontally from a 1.2 m high table and lands 0.68 m from the base, what was the speed at which it left the table?
- (A) 1.4 m/s  
 (B) 1.9 m/s  
 (C) 2.8 m/s  
 (D) 5.7 m/s

9. A rock is launched with a horizontal velocity of 3.0 m/s and a vertical velocity of 4.0 m/s. What is the magnitude of the velocity of the rock at its maximum height?
- (A) 0 m/s  
 (B) 3.0 m/s  
 (C) 4.0 m/s  
 (D) 5.0 m/s

10. Marble A and marble B roll off a tabletop simultaneously. At that instant marble B is moving twice as fast as marble A. Which statement below is true?
- (A) marble B reaches the floor first  
 (B) the marbles land at the same distance from the table legs  
 (C) the marbles have the same horizontal velocity  
 (D) the marbles have the same downward velocity

11. What is the time of flight for a projectile that is launched from ground level with an initial velocity of 65 m/s at  $30^\circ$  above the horizontal?
- (A) 3.6 s  
 (B) 6.6 s  
 (C) 11 s  
 (D) 13 s

12. The diagram below shows a projectile moving with speed,  $v$ , at the top of its path. Which vector best represents the acceleration of the projectile at position A?

- (A)   
 (B)   
 (C)   
 (D) 

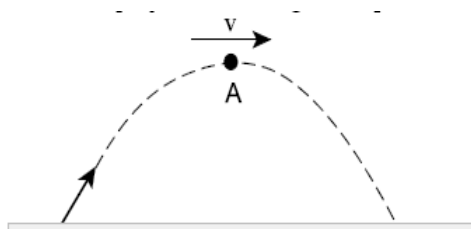

13. A block of mass  $m$  on a frictionless surface is attached to a hanging 5.0 kg mass as shown below. The system accelerates at  $2.6 \text{ m/s}^2$ . What is the mass of the block?

- (A) 1.3 kg  
 (B) 14 kg  
 (C) 19 kg  
 (D) 24 kg

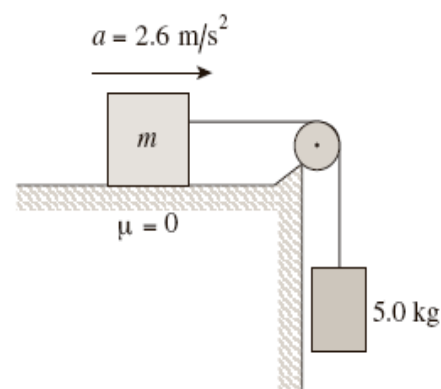

14. A block slides down an incline plane at a constant velocity of 6.0 m/s. What is the coefficient of kinetic friction if the incline plane makes an angle of  $25^\circ$  with the horizontal?
- (A) 0.37  
 (B) 0.42  
 (C) 0.47  
 (D) 0.91

15. In the diagram shown, the acceleration of the system is  $4.6 \text{ m/s}^2$ . What is the force of friction acting on the 6.0 kg box?
- (A) 14 N  
 (B) 42 N  
 (C) 64 N  
 (D) 78 N

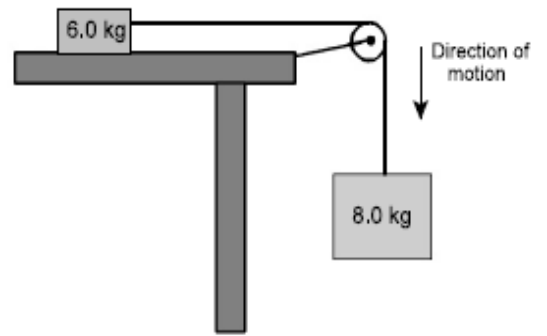

16. What normal force acts on the object shown, when it is pulled to the right on a frictionless surface by a force of 211 N at an angle of  $25.0^\circ$  to the horizontal?
- (A) 201 N  
 (B) 303 N  
 (C) 392 N  
 (D) 481 N

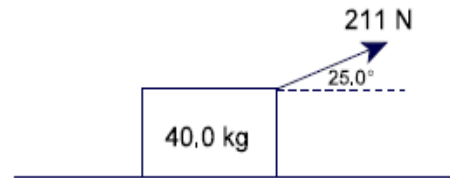

17. If the box shown slides down the frictionless incline with an acceleration of  $4.90 \text{ m/s}^2$ , what is the angle of the incline?
- (A)  $15.0^\circ$   
 (B)  $30.0^\circ$   
 (C)  $45.0^\circ$   
 (D)  $60.0^\circ$

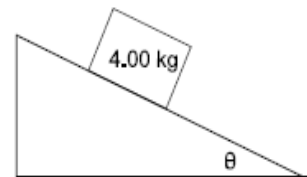

18. A 6.0 kg block is on an incline. The friction force acting on the block is 25 N. What is the magnitude of the block's acceleration?
- (A)  $1.3 \text{ m/s}^2$   
 (B)  $2.0 \text{ m/s}^2$   
 (C)  $4.0 \text{ m/s}^2$   
 (D)  $5.6 \text{ m/s}^2$

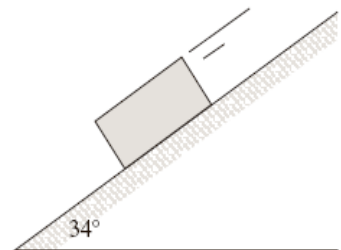

19. A box is held at rest on a frictionless incline as shown below. What is the tension, T, in the rope?
- (A) 29 N  
 (B) 32 N  
 (C) 62 N  
 (D) 69 N

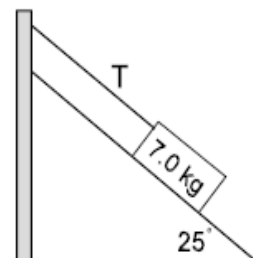

20. A block of mass M slides down an incline having a coefficient of kinetic friction,  $\mu_k$ . What is the acceleration of the block?
- (A)  $Mg\sin\theta$   
 (B)  $g\sin\theta - \mu_k g$   
 (C)  $g(\sin\theta - \mu_k \cos\theta)$   
 (D)  $g(\cos\theta - \mu_k \sin\theta)$

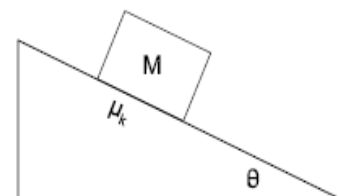

21. Two masses are connected together by a rope and pulley on a frictionless inclined plane as shown below. When the system is released, the 21 kg mass slides down the incline. What is the magnitude of the acceleration of the 21 kg mass?
- (A)  $0.26 \text{ m/s}^2$   
 (B)  $0.48 \text{ m/s}^2$   
 (C)  $9.3 \text{ m/s}^2$   
 (D)  $17 \text{ m/s}^2$

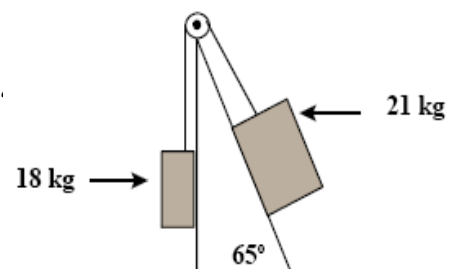

22. A box is pushed up a frictionless inclined plane as shown below. Which free body diagram represents this situation?

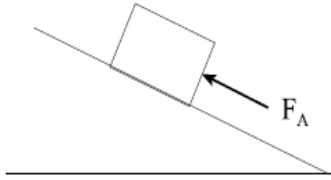

(A)



(B)



(C)

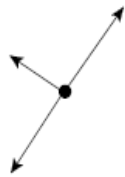

(D)



23. An object, of mass  $M$ , is hanging by a string from the ceiling of an elevator that is accelerating upwards at  $0.98 \text{ m/s}^2$ . What is the tension in the string?
- (A)  $Mg$   
 (B)  $0.9 Mg$   
 (C)  $1.1 Mg$   
 (D)  $2 Mg$

24. A block is launched up a frictionless incline with an initial speed of  $5.5 \text{ m/s}$  as shown. What is the maximum displacement,  $d$ , of the block up the incline?

- (A)  $0.44 \text{ m}$   
 (B)  $1.5 \text{ m}$   
 (C)  $2.0 \text{ m}$   
 (D)  $2.4 \text{ m}$

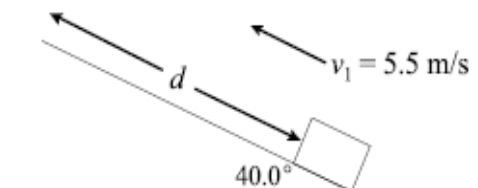

25. A rubber stopper spins in a horizontal circle on the end of a  $1.2 \text{ m}$  long string. If the stopper moves at a speed of  $3.2 \text{ m/s}$ , what is its acceleration?

- (A)  $0.12 \text{ m/s}^2$   
 (B)  $0.38 \text{ m/s}^2$   
 (C)  $2.7 \text{ m/s}^2$   
 (D)  $8.5 \text{ m/s}^2$

26. An object of mass  $20.0 \text{ kg}$  undergoes  $50$  rotations in  $25 \text{ s}$  making a circle of radius  $0.95 \text{ m}$ . What is the centripetal force experienced by the object?

- (A)  $1.9 \times 10^2 \text{ N}$   
 (B)  $2.5 \times 10^2 \text{ N}$   
 (C)  $1.5 \times 10^3 \text{ N}$   
 (D)  $3.0 \times 10^3 \text{ N}$

27. The diagram below shows a ball on the end of a string moving at a constant speed in a horizontal circle. A target is located near the path of the ball as shown. At which point should the ball be released in order to hit the target?
- (A) A  
(B) B  
(C) C  
(D) D

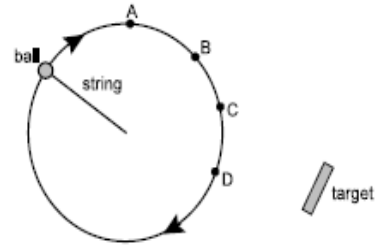

28. What is the speed of a planet that travels in a circular path of radius  $3.85 \times 10^8$  m, and has a period of 27.3 days?
- (A)  $5.13 \times 10^2$  m/s  
(B)  $1.03 \times 10^3$  m/s  
(C)  $2.46 \times 10^4$  m/s  
(D)  $2.80 \times 10^4$  m/s

29. The diagram below shows a ball, suspended by a string, traveling in a horizontal circular path at a constant speed. Which is the free body diagram for the ball at P?

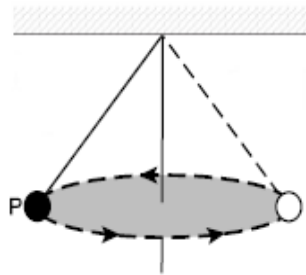

- (A)
- (B)
- (C)
- (D)

30. A pilot moving at a speed of  $2.50 \times 10^2$  m/s, experiences a normal force of seven times his weight at the bottom of a vertical dive. What is the radius of curvature of the dive if it follows a semi-circular path as shown?
- (A) 425 m  
(B) 797 m  
(C) 911 m  
(D) 1060 m



31. A small spider is accidentally taking a ride on a CD rotating with a period  $T$ . Its centripetal acceleration is  $10 \text{ m/s}^2$ . The CD player is turned off and the disc slows down. What is the spider's centripetal acceleration when the disc has slowed so the period is  $2T$ ?
- (A)  $2.5 \text{ m/s}^2$   
(B)  $5.0 \text{ m/s}^2$   
(C)  $20 \text{ m/s}^2$   
(D)  $40 \text{ m/s}^2$

32. A 4.0 kg ball on a string is swung in a horizontal circle at a speed of 3.5 m/s. If the tension in the string is 51 N, what is the radius of the circular path traced out by the ball?
- (A) 0.43 m  
 (B) 0.67 m  
 (C) 1.3 m  
 (D) 1.5 m

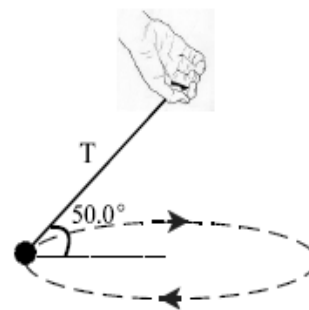

33. An object is in uniform horizontal circular motion.

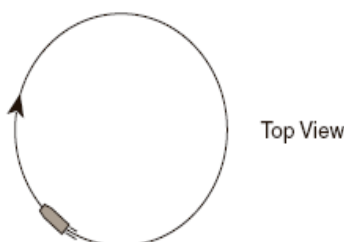

Which of the following shows the correct direction for the velocity, centripetal acceleration, and centripetal force on the object at the point shown?

	DIRECTION OF THE VELOCITY	DIRECTION OF THE CENTRIPETAL ACCELERATION	DIRECTION OF THE CENTRIPETAL FORCE
A.			
B.			
C.			
D.			

34. A car travels at 25 m/s along a horizontal curve of radius 450 m. What minimum coefficient of friction is necessary between its tires and the road in order for the car not to skid?
- (A) 0.14  
 (B) 0.54  
 (C) 0.72  
 (D) 1.4
35. Which is true for an object undergoing uniform circular motion?
- (A) Its acceleration is always directed tangent to the circle.  
 (B) Its speed and distance from the center of the circle is constant.  
 (C) Its velocity is always directed toward the center of the circle.  
 (D) Its velocity is constant.
36. A 0.300-kg mass, attached to the end of a 0.750 m string, is whirled around on a smooth level table. If the maximum tension that the string can withstand is 250.0 N, what is the maximum allowable rpm's?
- (A) 247 rpm  
 (B) 285 rpm  
 (C) 318 rpm  
 (D) 416 rpm
37. A ball on a string is spun in a horizontal circle. If the speed remains constant and the radius is halved, by what factor will the centripetal acceleration change?
- (A)  $\frac{1}{4}$   
 (B)  $\frac{1}{2}$   
 (C) 2  
 (D) 4

38. Why is a physics exam booklet lying on a table in front of you in translational equilibrium?
- (A) Surface friction is preventing it from sliding.  
 (B) The forces acting on it are balanced.  
 (C) The force due to gravity is holding it down.  
 (D) There are no forces acting on it.

39. A 45 N force is applied at an angle of  $35^\circ$  to a door at a distance of 0.75 m from the hinge. What is the magnitude of the torque produced by this force?
- (A) 19 Nm  
 (B) 28 Nm  
 (C) 34 Nm  
 (D) 45 Nm

40. For the suspended mass shown below, what is the magnitude of the tension,  $T$ , in each cable?
- (A) 123 N  
 (B) 162 N  
 (C) 187 N  
 (D) 373 N

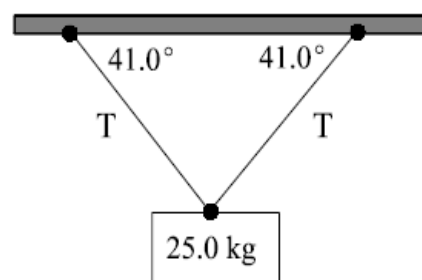

41. Two students are balanced on a uniform seesaw that is supported at the center. If student X with mass 65 kg is 1.2 m from the pivot point on one side of the seesaw, how far from the pivot point is student Y with mass 55 kg?
- (A) 0.71 m  
 (B) 1.0 m  
 (C) 1.2 m  
 (D) 1.4 m

42. If the 3.20 kg uniform beam shown is in static equilibrium, what is the magnitude of  $F_2$ ?
- (A) 13.9 N  
 (B) 20.2 N  
 (C) 40.3 N  
 (D) 80.6 N

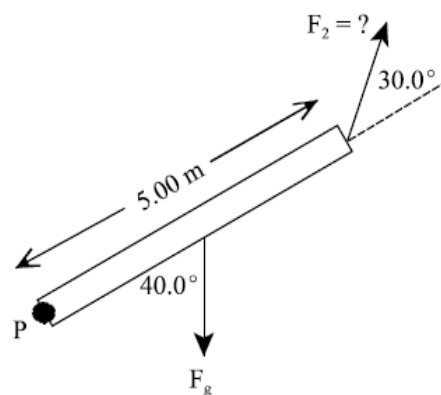

43. Which defines static equilibrium?
- (A)  $\vec{F}_{net} \neq 0, \vec{\tau}_{net} \neq 0$   
 (B)  $\vec{F}_{net} \neq 0, \vec{\tau}_{net} = 0$   
 (C)  $\vec{F}_{net} = 0, \vec{\tau}_{net} \neq 0$   
 (D)  $\vec{F}_{net} = 0, \vec{\tau}_{net} = 0$

44. An 8.50 m long uniform beam of weight 126 N is supported by a rope at each end. If a 433 N person sits 2.00 m from the left end, what is the tension,  $T$ , in the rope on the right?
- (A) 102 N  
 (B) 165 N  
 (C) 228 N  
 (D) 559 N

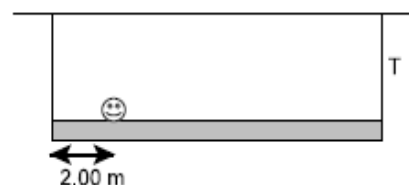

45. An object is suspended by two ropes from a ceiling and a wall as shown. What is the tension,  $T_1$ , in the rope connected to the ceiling?
- (A) 139 N  
 (B) 214 N  
 (C) 304 N  
 (D) 468 N

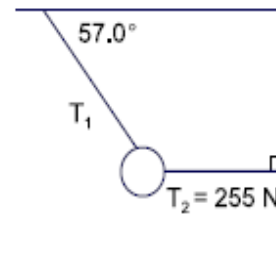

46. A uniform 45 kg beam of length 3.0 m is supported as shown. What is the tension  $T$  in the cable?
- (A) 220 N  
 (B) 280 N  
 (C) 290 N  
 (D) 370 N

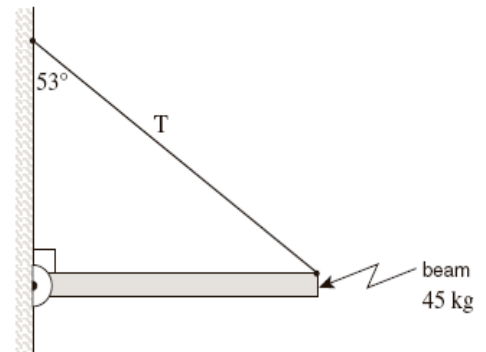

47. Which of the four problems shown requires the application of torque?

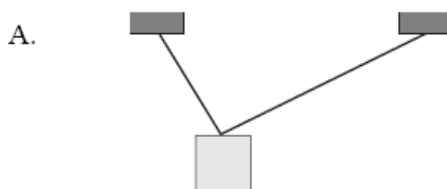

What is the tension in the supporting cables?

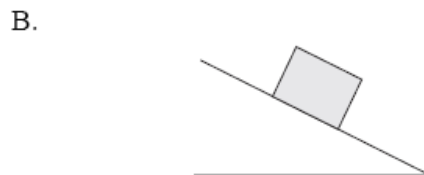

What is the friction force acting on the block?



What is the acceleration of the puck?

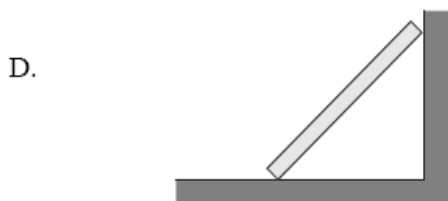

What force does the wall exert on the board?

48. In which direction should a force act on the boom so that it creates a **minimum** torque about the hinge?
- (A) W  
 (B) X  
 (C) Y  
 (D) Z

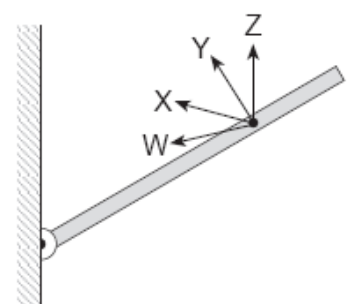

49. A uniform 16 m long plank weighing 350 N rests on supports 8.0 m apart. An 850 N man walks along the plank to the right. How far past point B can the man walk before the plank tips?
- (A) 0.82 m  
 (B) 1.6 m  
 (C) 2.5 m  
 (D) 3.3 m

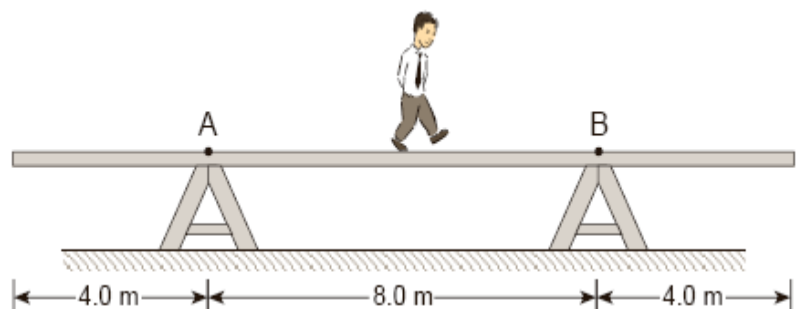

50. A 5.0 kg mass is suspended by a rope. A horizontally directed force  $F$  is applied to the mass. What magnitude of force is needed to produce an angle of  $\theta = 65^\circ$ ?
- (A) 21 N  
 (B) 23 N  
 (C) 44 N  
 (D) 110 N

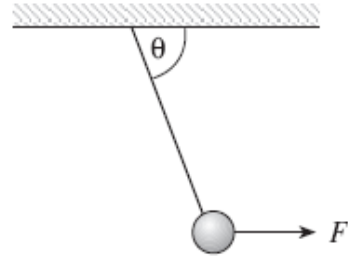

**PART II**  
**Total Value: 50%**

**Instructions:** Complete all items in this section. Your responses should be clearly presented in a well organized manner with proper use of units, formulae and significant figures where appropriate.

Value

- 4% 51. (a) A strike in baseball occurs between 0.50 m and 1.0 m directly above home plate. A pitcher, 18.0 m from home plate, throws a ball with an initial velocity of 17.0 m/s at  $15^\circ$  above the horizontal. If the ball is released 2.0 m above the ground, will the pitch be a strike? Show workings.

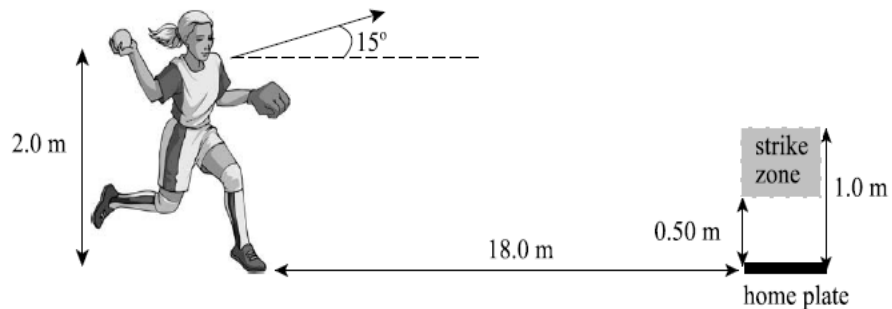

3%

- (b) A juggler throws a ball upward at an angle of  $65^\circ$  to the horizontal, with an initial speed of 3.2 m/s. How far apart should the juggler hold her hands in order to catch the ball at the same level from which it was thrown?

5%

- (c) A ball rolls off an incline at  $20.0 \text{ m/s}$ , as shown in the diagram below. At what horizontal distance from the wall will the ball hit the ground?

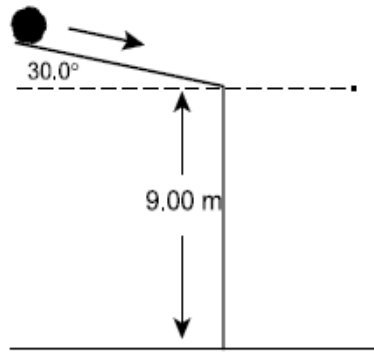

3%

52. (a) The diagram below shows two blocks connected by a massless string over a frictionless pulley. Calculate the acceleration of the system of blocks.

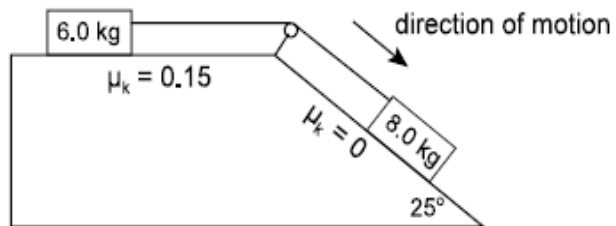

(b) A 5.0 kg block is laid flat on an horizontal table ( $\mu_k = 0.10$ ). The block is pulled to the right with a force of 25 N, at  $15^\circ$  above the horizontal.

2%

(i) Sketch the free body diagram.

4%

(ii) What is the magnitude of the acceleration of the block?

4%

(c) A skier starts from rest and begins descending a  $30.0^\circ$  slope. The coefficient of kinetic friction is 0.10.

(i) What is the acceleration of the skier? Include a free body diagram.

(ii) How far down the slope will the skier travel in 10.0 s?

3%

53.

(a) In an automatic clothes dryer a hollow drum moves the clothes in a vertical circle of diameter 0.75 m. The dryer is designed so that the clothes tumble and do not simply stick to the drum as it rotates. Calculate the speed at which the drum must rotate so that a 0.425 kg sweater at the top of the drum will just begin to tumble.

4%

(b) A car is rounding a flat, horizontal turn with radius 51 m. The coefficient of friction between the tires and the road is 0.30.

i) Calculate the maximum speed at which the car can safely round the turn without skidding.

ii) Calculate the angle at which the road must be banked so that the car can safely round the turn when there is no friction between the tires and the road.

3%

(d) Tarzan plans to cross a gorge by swinging in an arc from a hanging vine. If his arms are capable of exerting a force of 1200 N on the rope, what is the maximum speed he can tolerate at the lowest point of his swing? His mass is 85kg and the vine is 4.8 m long.

4%

54. (a) In the diagram below, spring scales are used to measure the tension in each string supporting the 1.95 kg mass. Calculate whether the system is in static equilibrium.

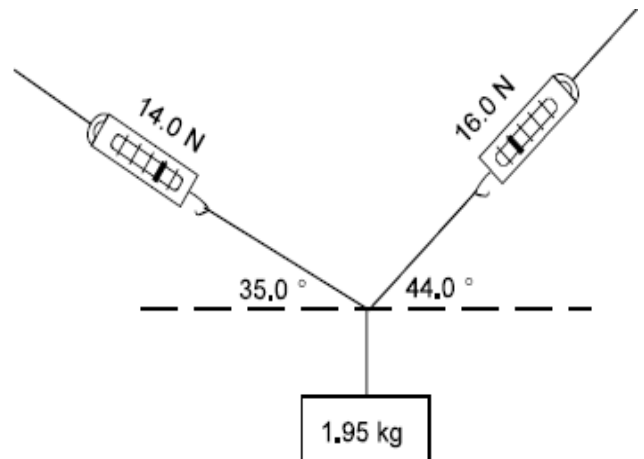

4%

- (b) A 4.00 m long uniform beam is supported by a pivot at one end and a cable at the other end. The beam has a mass of 15.0 kg and supports a 25.0 kg box as shown. Calculate the tension,  $T$ , in the cable.

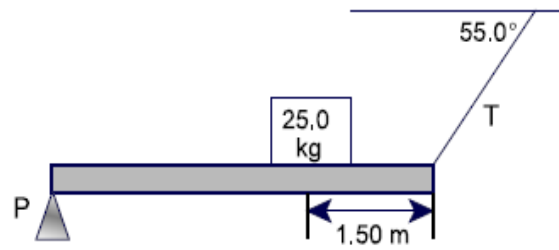

- (c) A 20.0 kg sign is supported at the end of a 2.50 m horizontal beam of mass 21.0 kg that is hinged to a pole as shown.

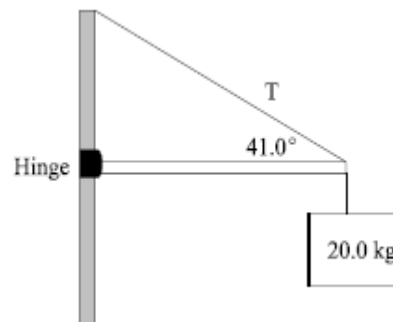

4%

- i) Calculate the magnitude of the tension in the cable.

3%

- ii) Calculate the magnitude of the horizontal component of the force exerted on the beam by the hinge.