

## midterm review unit 1

### Multiple Choice

Identify the choice that best completes the statement or answers the question.

- \_\_\_ 1. Convert 24 yd. to feet.  
a. 288 ft.                      b. 72 ft.                      c. 2 ft.                      d. 8 ft.
- \_\_\_ 2. Convert 7 yd. to inches.  
a. 21 in.                      b. 252 in.                      c. 43 in.                      d. 84 in.
- \_\_\_ 3. Convert 100 in. to yards, feet, and inches.  
a. 4 yd. 2 ft. 2 in.                      c. 1 yd. 1 ft. 4 in.  
b. 2 yd. 2 ft. 4 in.                      d. 4 yd. 0 ft. 4 in.
- \_\_\_ 4. Convert 12 565 ft. to miles, yards, and feet.  
a. 6 mi. 167 yd. 1 ft.                      c. 2 mi. 668 yd. 1 ft.  
b. 2 mi. 55 yd. 25 ft.                      d. 6 mi. 668 yd. 1 ft.
- \_\_\_ 5. Marie has 17 yd. of material that she will cut into strips 19 in. wide. How many strips can Marie make?  
a. 32                      b. 21                      c. 2                      d. 10
- \_\_\_ 6. Nancy has 7 yd. of material. She wants to make curtains that are 18 in. wide. How many curtains can Nancy make?  
a. 92                      b. 14                      c. 4                      d. 1
- \_\_\_ 7. Oscar is building a fence around his rectangular garden. His garden measures 18 ft. 6 in. by 8 ft. 5 in. The fencing material is sold by the yard. It costs \$3.75/yd. What is the cost of material before taxes?  
a. \$66.25                      b. \$63.75                      c. \$67.50                      d. \$33.75
- \_\_\_ 8. Paul plans to replace 487 in. of wood railing along the top of his patio fence. The wood is sold in 8-ft. lengths. How many 8-ft. lengths does Paul need to purchase?  
a. 61                      b. 7                      c. 5                      d. 6
- \_\_\_ 9. Mike ran 1 mi. in 4 min. On average, how far did he run every 10 s? Give your answer in yards and feet.  
a. 73 yd. 1 ft.                      c. 220 yd. 0 ft.  
b. 7 yd. 1 ft.                      d. 293 yd. 1 ft.
- \_\_\_ 10. Which referent could you use for 1 m?  
a. The width of a computer keyboard  
b. The length of a dinner fork  
c. The length of your stride  
d. The width of a classroom in your school
- \_\_\_ 11. Which referent could you use for 1 km?  
a. The distance equal to  $2\frac{1}{2}$  laps on an oval running track  
b. The length of an iPod  
c. The length of a snowboard  
d. The length of your arm span
- \_\_\_ 12. Which referent could you use for 1 mm?  
a. The width of the head of an ant

- b. The diameter of a beach ball
- c. The distance between British Columbia and Manitoba
- d. The length of a sheet of loose-leaf paper

- \_\_\_ 13. Which SI unit is most appropriate for measuring the width of your desk?  
 a. Kilometres      b. Centimetres      c. Metres      d. Millimetres
- \_\_\_ 14. Which imperial unit is most appropriate for measuring the length of a hockey rink?  
 a. Miles      b. Feet      c. Yards      d. Inches
- \_\_\_ 15. Which imperial unit is most appropriate for measuring the width of a snowboard?  
 a. Miles      b. Inches      c. Feet      d. Yards
- \_\_\_ 16. A penalty box on a soccer field measures 44 yd. by 18 yd. What are these dimensions to the nearest tenth of a metre?  
 a. 39.6 m by 16.2 m      c. 39.6 m by 17.6 m  
 b. 47.7 m by 16.2 m      d. 47.7 m by 17.6 m
- \_\_\_ 17. The Skeena River is the second longest river entirely in B.C. It is approximately 354 mi. long. What is this length to the nearest kilometre?  
 a. 566 km      b. 212 km      c. 590 km      d. 221 km
- \_\_\_ 18. On a road map of British Columbia, the distance between Vancouver and Fort St. John is 1237 km. What is this distance to the nearest mile?  
 a. 742 mi.      b. 673 mi.      c. 1979 mi.      d. 2061 mi.
- \_\_\_ 19. A thin strip of wood laminate is to be glued to the edges of a table. The length of laminate required is equal to the perimeter of the table, which has dimensions 175 cm by 110 cm. The laminate is sold in 8-ft. lengths. How much laminate must be purchased?  
 a. 24 ft.      b. 32 ft.      c. 16 ft.      d. 8 ft.
- \_\_\_ 20. Determine the surface area of this right rectangular pyramid to the nearest square inch.

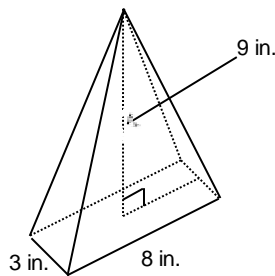

- a. 127 square inches      c. 229 square inches
- b. 103 square inches      d. 75 square inches

- \_\_\_ 21. Determine the surface area of this right cone to the nearest square metre.

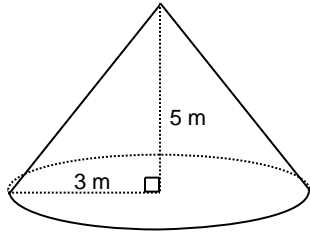

- a.  $74 \text{ m}^2$       b.  $55 \text{ m}^2$       c.  $75 \text{ m}^2$       d.  $83 \text{ m}^2$

- \_\_\_ 22. The lateral area of a cone is  $198.6 \text{ cm}^2$ . The diameter of the cone is  $10.2 \text{ cm}$ . Determine the height of the cone to the nearest tenth of a centimetre.  
 a.  $8.8 \text{ cm}$       b.  $11.3 \text{ cm}$       c.  $8.0 \text{ cm}$       d.  $12.4 \text{ cm}$
- \_\_\_ 23. The slant height of a right square pyramid is  $17 \text{ ft}$ . and the side length of the base is  $13 \text{ ft}$ . Determine its lateral area to the nearest square foot.  
 a.  $442 \text{ square feet}$       b.  $408 \text{ square feet}$       c.  $884 \text{ square feet}$       d.  $111 \text{ square feet}$
- \_\_\_ 24. A right cone has a height of  $15 \text{ in.}$  and a base diameter of  $8 \text{ in.}$  Determine the lateral area of the cone to the nearest square inch.  
 a.  $188 \text{ square inches}$       c.  $245 \text{ square inches}$   
 b.  $195 \text{ square inches}$       d.  $214 \text{ square inches}$
- \_\_\_ 25. The surface area of a right cone is  $400.2 \text{ m}^2$ . The radius of the cone is  $6.0 \text{ m}$ . Determine the height of the cone to the nearest metre.  
 a.  $14 \text{ m}$       b.  $16 \text{ m}$       c.  $15 \text{ m}$       d.  $13 \text{ m}$
- \_\_\_ 26. A right cone has a height of  $13 \text{ cm}$  and a base diameter of  $17 \text{ cm}$ . Determine the surface area of the cone to the nearest square centimetre.  
 a.  $642 \text{ cm}^2$       b.  $574 \text{ cm}^2$       c.  $415 \text{ cm}^2$       d.  $1057 \text{ cm}^2$
- \_\_\_ 27. Calculate the slant height,  $s$ , of this right square pyramid to the nearest tenth of a centimetre.

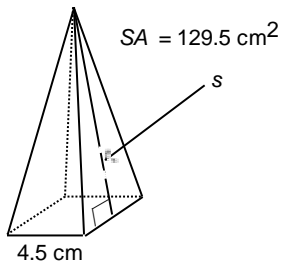

- a.  $11.9 \text{ cm}$       b.  $6.1 \text{ cm}$       c.  $12.1 \text{ cm}$       d.  $16.6 \text{ cm}$

- \_\_\_ 28. Calculate the volume of this right square pyramid to the nearest cubic foot.

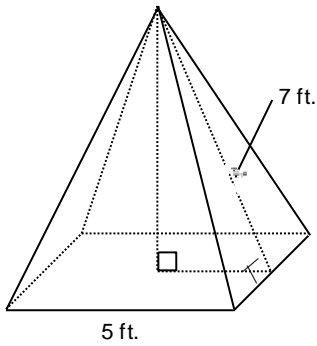

- a. 58 cubic feet      b. 62 cubic feet      c. 54 cubic feet      d. 163 cubic feet

\_\_\_ 29. Calculate the volume of this right cone to the nearest tenth of a cubic metre.

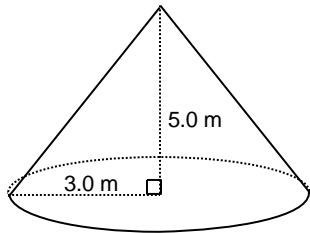

- a.  $141.4 \text{ m}^3$       b.  $47.1 \text{ m}^3$       c.  $49.3 \text{ m}^3$       d.  $55.0 \text{ m}^3$

\_\_\_ 30. A right rectangular prism with base dimensions 7.8 m by 5.1 m has a volume of  $110.1 \text{ m}^3$ . Determine the height of the prism to the nearest tenth of a metre.

- a. 2.8 m      b. 8.3 m      c. 1.2 m      d. 5.5 m

\_\_\_ 31. A right cone has a height of 8 cm and a volume of  $250 \text{ cm}^3$ . Determine the radius of the base of the cone to the nearest centimetre.

- a. 3 cm      b. 11 cm      c. 17 cm      d. 5 cm

\_\_\_ 32. A right cylindrical can has a volume of  $263.1 \text{ cm}^3$ . What is the volume of a right cone with the same base and the same height, to the nearest tenth of a centimetre?

- a. 131.6 cm      b. 91.7 cm      c. 89.7 cm      d. 87.7 cm

\_\_\_ 33. The volume of this right cone is  $14.7 \text{ mm}^3$ . Calculate its height,  $h$ , to the nearest tenth of a millimetre.

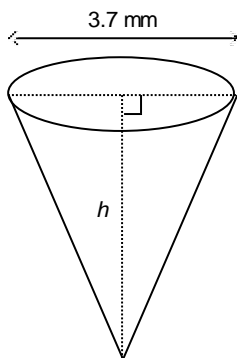

- a. 4.1 mm                      b. 1.0 mm                      c. 1.4 mm                      d. 2.8 mm

- \_\_\_ 34. The surface area of a tennis ball is approximately 23 square inches. What is the diameter of the tennis ball to the nearest inch?  
 a. 3 in.                      b. 1 in.                      c. 4 in.                      d. 6 in.
- \_\_\_ 35. A hemisphere has radius 11.6 cm. What is the surface area of the hemisphere to the nearest tenth of a square centimetre?  
 a. 1268.2 cm<sup>2</sup>                      b. 3269.1 cm<sup>2</sup>                      c. 918.4 cm<sup>2</sup>                      d. 845.5 cm<sup>2</sup>
- \_\_\_ 36. The circumference of a medicine ball is 28 in. Determine its surface area to the nearest square inch.  
 a. 998 square inches                      c. 111 square inches  
 b. 250 square inches                      d. 371 square inches
- \_\_\_ 37. A stadium has a roof that approximates a hemisphere with circumference 2500 ft. Determine the surface area of the roof to the nearest square foot.  
 a. 131 928 625 square feet                      c. 1 492 078 square feet  
 b. 3 978 874 square feet                      d. 994 718 square feet
- \_\_\_ 38. Determine the surface area of this composite object, which is a right cylinder and a hemisphere, to the nearest tenth of a square metre.

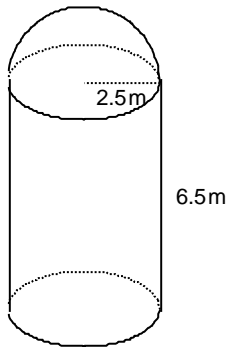

- a. 200.3 m<sup>2</sup>                      b. 180.6 m<sup>2</sup>                      c. 141.4 m<sup>2</sup>                      d. 161.0 m<sup>2</sup>

- \_\_\_ 39. A garden shed is a composite object formed by a right rectangular prism with a right triangular prism as its roof. Determine the surface area of the garden shed to the nearest square foot.

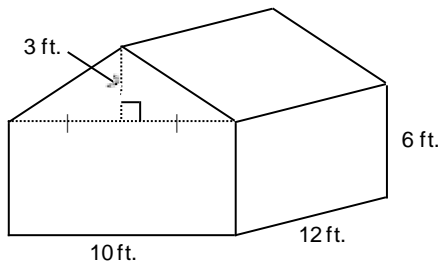

- a. 366 square feet                      b. 554 square feet                      c. 434 square feet                      d. 464 square feet

- \_\_\_ 40. Determine the volume of this composite object, which is a right cylinder and two right cones, to the nearest cubic centimetre.

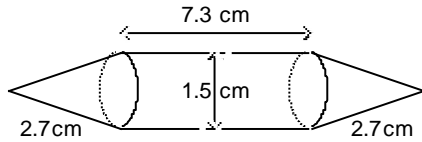

- a.  $37 \text{ cm}^3$       b.  $16 \text{ cm}^3$       c.  $14 \text{ cm}^3$       d.  $47 \text{ cm}^3$

### Short Answer

41. A killer whale is 8.5 m long. Convert this length to feet and the nearest inch.
42. Determine the surface area of this sphere to the nearest square centimetre. Determine its volume to the nearest cubic centimetre.

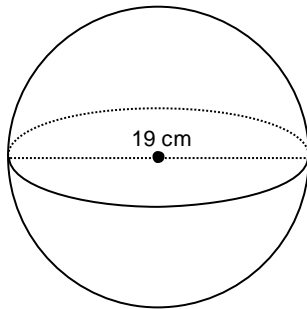

### Problem

43. Convert 28 yd. to feet. Use unit analysis to verify the conversion.
44. Explain how to convert a measurement of 20 000 ft. to miles, yards, and feet.
45. A fathom is a unit of length used to measure the depth of water. A fathom is equal to 6 ft.
- How many fathoms are in a mile?
  - Challenger Deep in the Pacific Ocean is the deepest point in Earth's oceans. It is 35 797 ft. below sea level. What is this depth to the nearest fathom? Is this depth greater than or less than 7 mi.? Explain.
46. Jaymee is 4 ft. 5 in. tall.
- What is Jaymee's height in centimetres? Write a proportion to determine your answer.
  - Use mental math and estimation to justify that the answer is reasonable.
47. In track and field, the 440-yd. race was replaced with the 400-m race when Canada changed from the imperial system to the SI system. Which race is longer and by how much? Use the exact conversion:  $1 \text{ yd.} = 91.44 \text{ cm}$
48. A hardware store sells nylon rope for  $\$0.89/\text{yd.}$  A lumber yard sells the same rope for  $\$0.94/\text{m.}$
- Which store sells the rope for a lower price? Explain your answer.
  - How much money would Jim save if he purchased 550 ft. of the less expensive rope, before taxes?

49. Three wooden blocks need to be painted. The first block is a right rectangular pyramid with base dimensions 1.5 cm by 2.5 cm and a height of 2.0 cm. The second block is a right square pyramid with a base length of 2.8 cm and a height of 2.0 cm. The third block is a right cone with a height of 2.0 cm and a base diameter of 3.6 cm. Which block requires the most paint? Which block requires the least paint? Sketch diagrams to help explain your answer.
50. A right rectangular pyramid has base dimensions 6 cm by 4 cm and a height of 8 cm. Determine its lateral area to the nearest square centimetre.
51. A right square pyramid has base perimeter 62.4 m and height 6.4 m. Calculate the volume of the pyramid to the nearest cubic metre.
52. Francis has three empty containers: a right rectangular prism, a right square pyramid, and a right cone. Each container has height 2.0 cm. The prism has base dimensions 1.5 cm by 2.5 cm. The pyramid has base side length 3.4 cm. The cone has base diameter 3.8 cm. Determine the volume of each container to the nearest tenth of a cubic centimetre. Which container has the least volume? Which container has the greatest volume? Explain your answer.
53. A candle approximates a sphere with circumference 21 cm. The surface of the candle is to be covered with glitter.
- Determine the radius of the candle to the nearest centimetre.
  - Determine the surface area of the candle to the nearest square centimetre.
54. A hemisphere has radius 23.3 m.
- Determine the surface area of the hemisphere to the nearest tenth of a square metre.
  - Determine the volume of the hemisphere to the nearest tenth of a cubic metre.
55. A baby's rattle contains a plastic ball inside a spherical case. The diameter of the plastic ball is 2 cm and the diameter of the case is 7 cm.

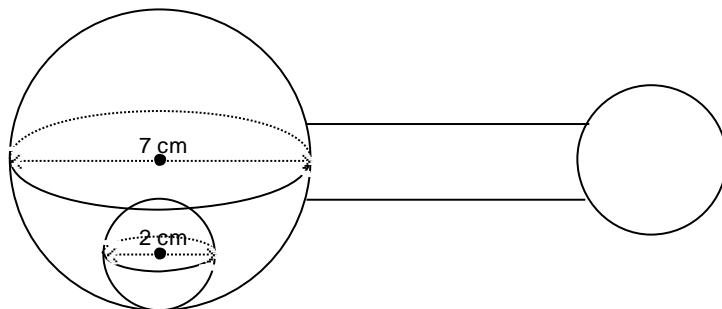

- Calculate the volume of the spherical case, to the nearest cubic centimetre.
  - Calculate the volume of the plastic ball, to the nearest cubic centimetre.
  - Calculate the volume of air in the rattle, to the nearest cubic centimetre.
56. Determine the surface area of this composite object, which is a right square prism and a right square pyramid, to the nearest square foot. Explain your answer.

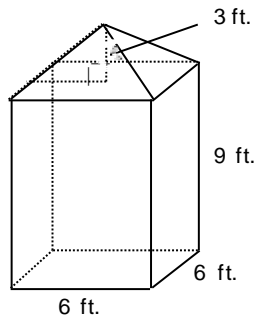

57. A solid sphere just fits inside a cube that has an edge length equal to the diameter of the sphere. The edge length of the cube is 4.9 cm. What is the volume of air in the cube to the nearest cubic centimetre?

